



# Organic Resources Recovery Centre Phase 1 - ORRC1 (also known as O·PARK1)

## Operational Guidelines for Registered Food Waste Collectors

April 2021

# Contents

	<u>Page</u>
1. Site Overview	1
2. Organic Waste (or Food Waste) Treatment Processes	2
3. Route to O·PARK1	3
4. Key Points of Collection and Delivery of Food Waste to O·PARK1	5
5. Food Waste Collection Vehicle Work Flow and Traffic Flow at O·PARK1	6
6. Food Waste Reception and Unloading	13
7. Testing and Commissioning Arrangement	19

## 1. Site Overview



- 1.Site entrance
- 2.Weighbridge
- 3.Main waste reception
- 4.Suspension buffer tank
- 5.Digester tank farm
- 6.Compost processing
- 7.Compost tunnels
- 8.Biogas conditioning
- 9.Biogas storage tank
- 10.Combined heat & power units (CHP)
- 11.Emergency flare
- 12.Ammonia stripping plant
- 13.Central air pollution control system
- 14.Waste water treatment plant
- 15.Offices, common facilities, visitor centre
- 16.Link walkway
- 17.Air control stack

## 2. Organic Waste (or Food Waste) Treatment Processes

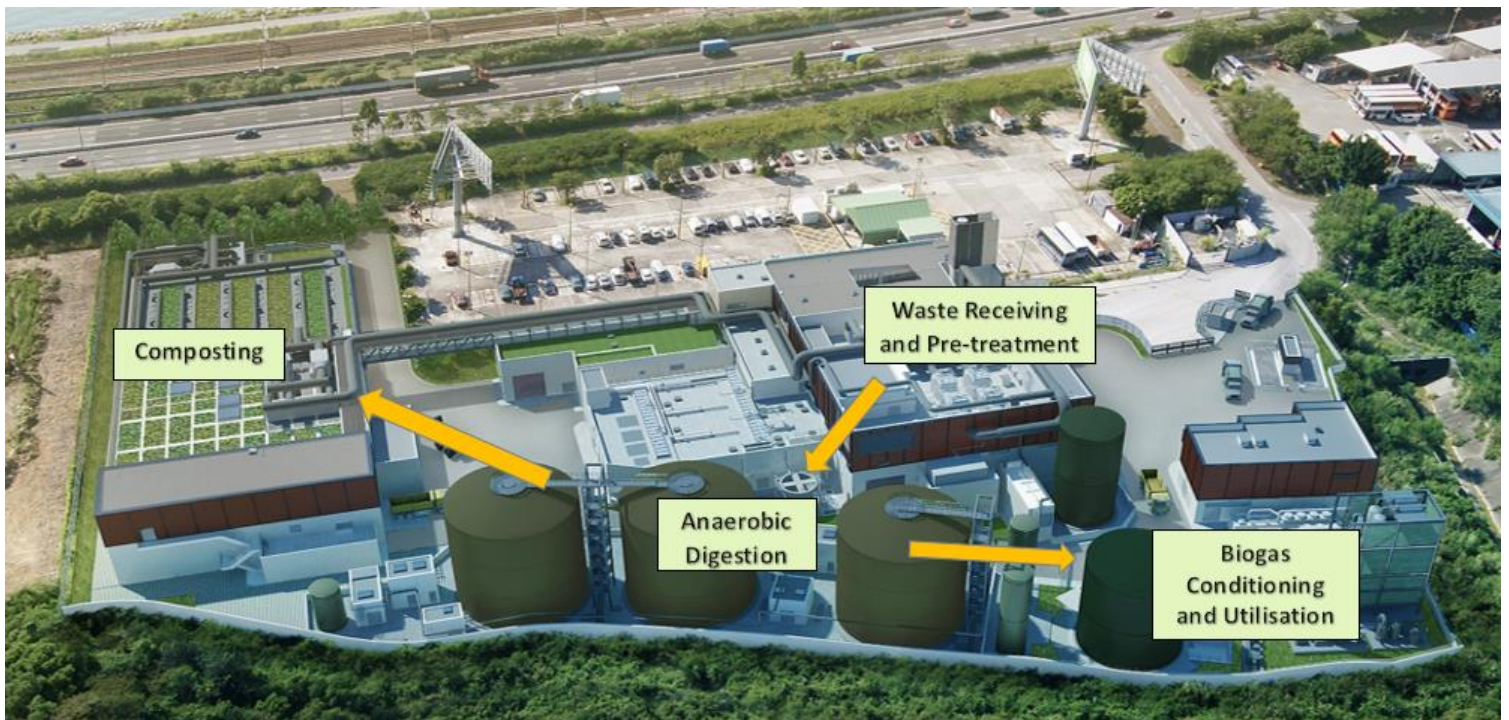
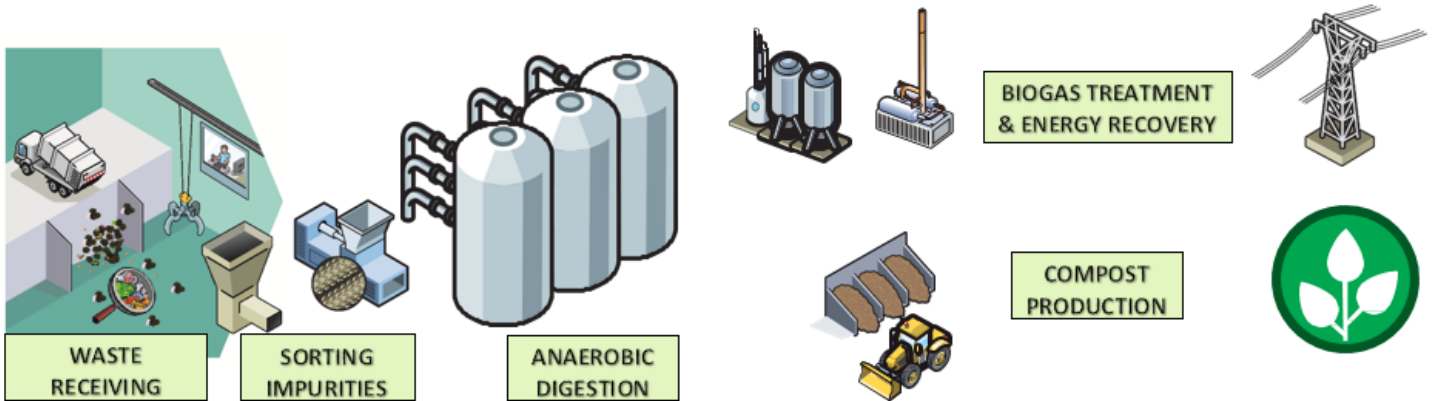

3. Route to O·PARK1

Address: 5 Sham Fung Road, Siu Ho Wan, North Lantau Island, N.T.

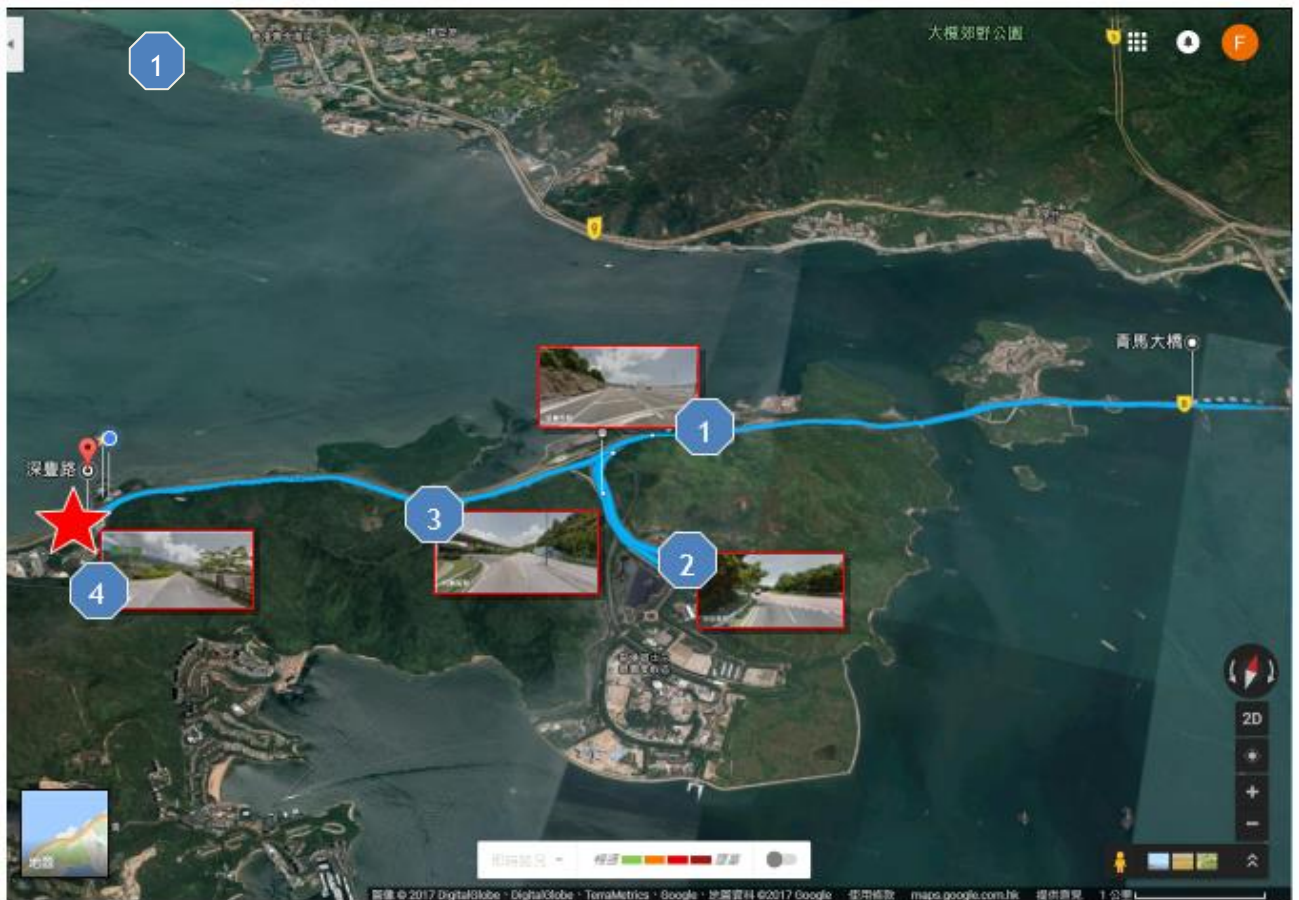

**(A) Travel from Tsing Yi Island via Tsing Ma Bridge**

- 1 Take exit 5 towards Penny's Bay Highway
- 2 At the roundabout, take the 1<sup>st</sup> exit onto Sunny Bay Road
- 3 Turn left onto Cheung Tung Road
- 4 Turn left onto Sham Fung Road





**(B) Travel from Airport / Tung Chung New Town**

- 1 At the roundabout, take the 3<sup>rd</sup> exit onto Shun Tung Road
- 2 Turn left onto Tat Tung Road
- 3 Turn left onto Fu Tung Street toward Cheung Tung Road
- 4 Turn right onto Sham Fung Road



#### 4. Key Points of Collection and Delivery of Food Waste to O·PARK1



Registered food waste collectors (RWCs) should display the identification label on the windshield of their food waste collection vehicles (FWCVs) when entering O·PARK1

Before the collection of source separated food waste (SSFW) at each collection point, RWCs should check to ensure the quality and quantity of SSFW can meet the requirements of O·PARK1 and complete the Food Waste Collection & Delivery Record Form

Food waste collection vehicles need to be leak-proof and will not cause odour nuisance

RWCs' frontline staff (i.e. drivers and workers) must follow these Guidelines when using O·PARK1 and they must **keep at least two** emergency contacts of RWC's senior management

If non-permitted waste is identified or SSFW contains more than 20% inert materials, EPD or O·PARK1 operator has the right to reject SSFW delivered to O·PARK1 and issue verbal warning or warning letter to RWCs. Moreover, EPD or O·PARK1 operator has the right to request RWC to divert the rejected SSFW to landfills or refuse transfer stations at their own cost

RWCs' frontline staff should cooperate with O·PARK1 staff during food waste sampling exercise for the determination of food waste characteristics

5. Food Waste Collection Vehicle (FWCV) Work Flow and Traffic Flow at O-PARK1

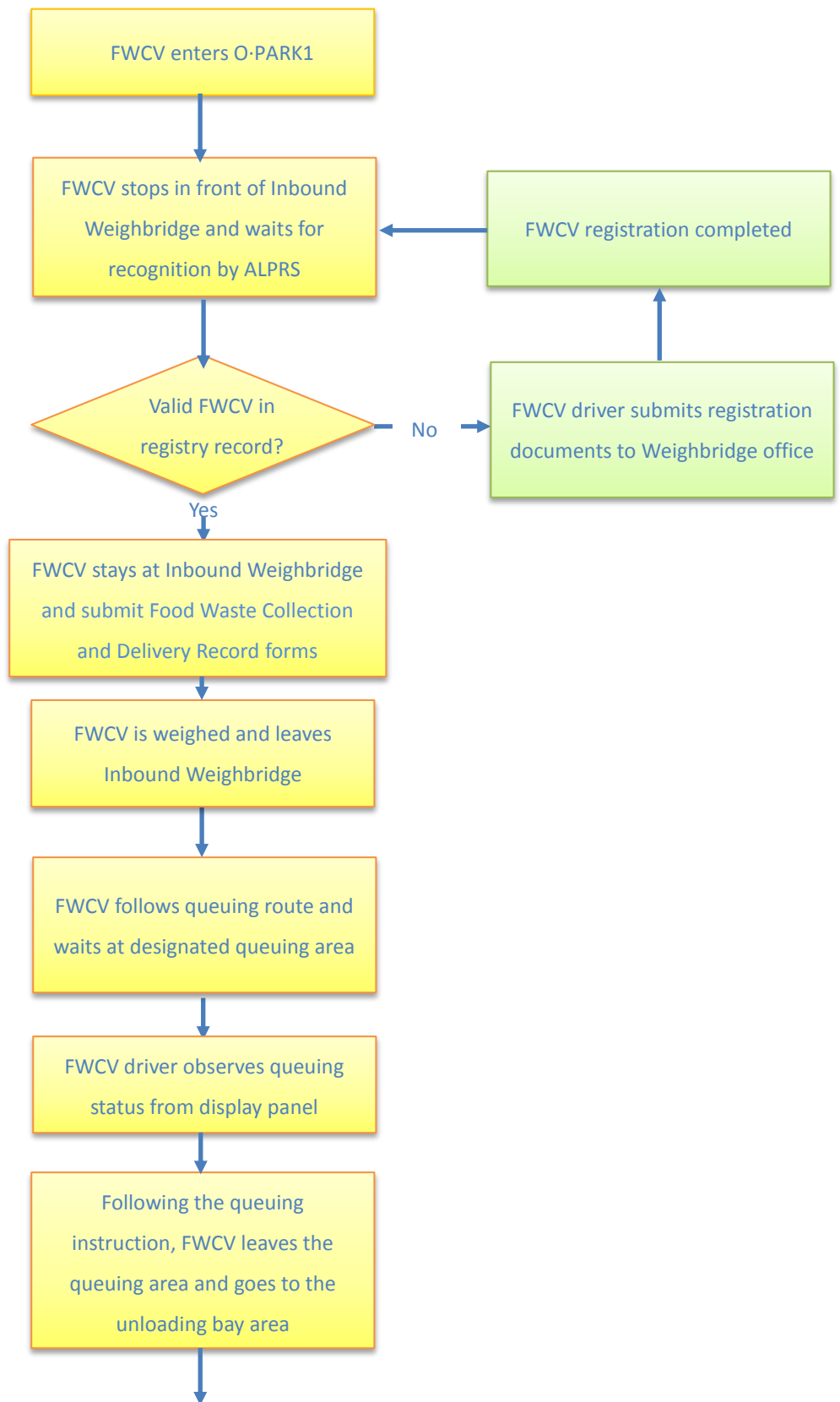

**Abbreviation**

FWCV: Food Waste Collection Vehicle

ALPRS: Automatic Licence Plate Recognition System

SSFW: Source Separated Food Waste



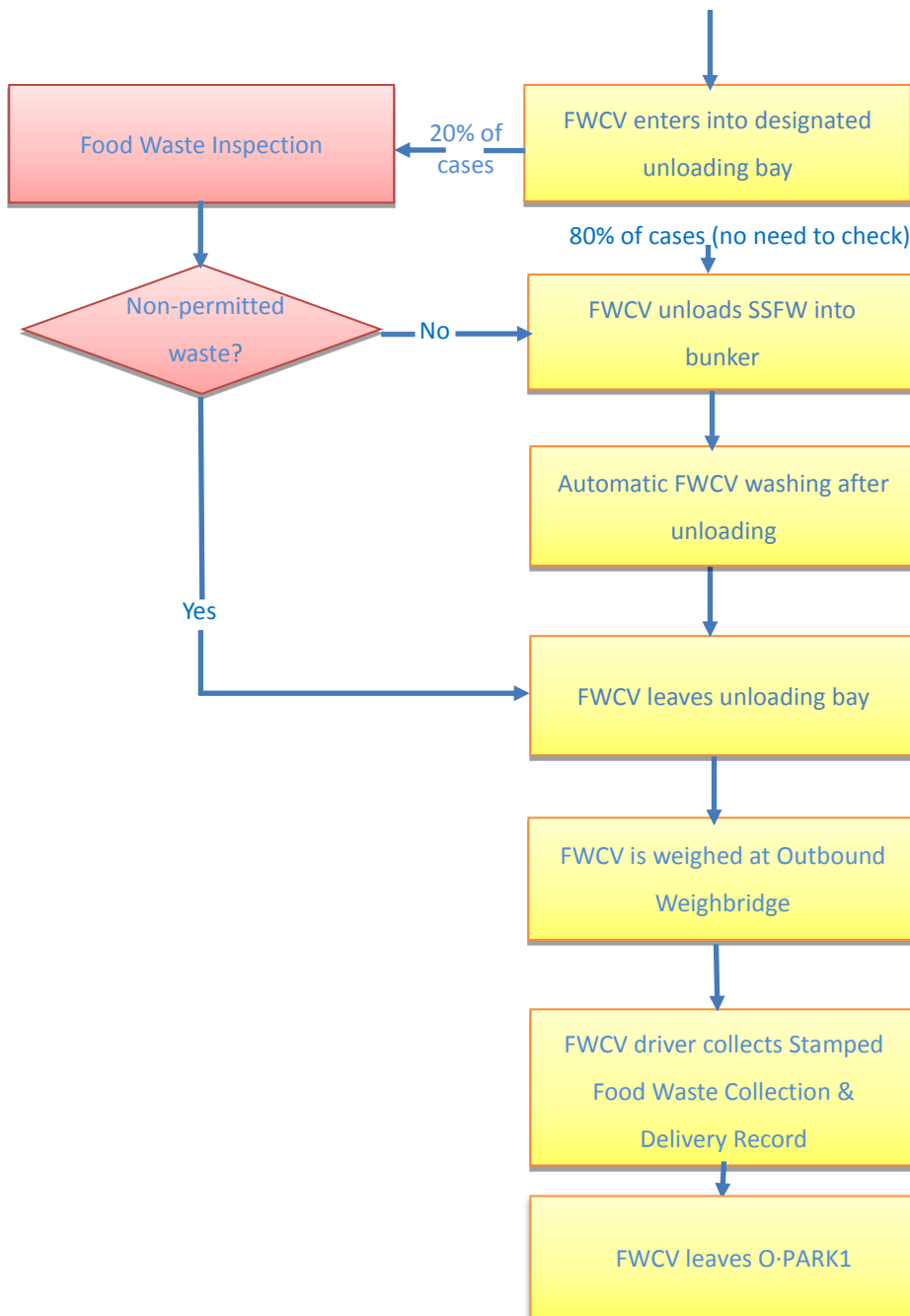

## 5.1 Safety Rules of Using O·PARK1

- (a) Open flames and smoking are strictly prohibited at O·PARK1;
- (b) All RFWCs' drivers and staff must wear appropriate Personal Protective Equipment (PPE) (e.g., reflective vests, safety shoes, safety helmets) when working inside the Facility;
- (c) Drivers should pay attention to the vehicle height limit of 4.5m;
- (d) Drivers should drive carefully and slowly when entering O·PARK1 and approach to the inbound weighbridge directly;
- (e) If the unloading bays are full and FWCVs are not able to approach to the bays directly, drivers should follow the queuing instructions and line up in the designated queuing area accordingly;
- (f) Unless otherwise instructed by O·PARK1 staff under special arrangement, drivers must follow the traffic light signals and signs at all time when driving within O·PARK1;
- (g) Except for performing work required and in accordance with this Guidelines, all drivers must stay inside the FWCV;
- (h) Drivers shall ensure there is no leakage of leachate and food waste from FWCV to keep O·PARK1 clean and tidy.

## 5.2 Driving Rules at O·PARK1

- (a) Speed

Driving speed shall not exceed 10 km/hr within the Facility. All vehicles shall maintain a safe clearance from the vehicle at the front. Maneuvering speed shall not exceed 5 km/hr when reversing;

**(b) Accident, Incident and Interruption**

If there is a traffic accident or vehicle breakdown at the Facility, drivers should not attempt to fix the vehicle without notifying O-PARK1 staff. Instead, drivers should immediately inform the O-PARK1 staff and their RFWCs' representatives for support and follow up;

**(c) When FWCV or SSFW Catches Fire**

If driver of FWCV and any collector's staff finds FWCV or SSFW catches fire, they should report to the O-PARK1 staff immediately and follow their instruction;

If a fire breaks out inside the unloading bay, driver can move the vehicle to an open space if he/she is safe to do so;

**(d) Horn**

Use horn only in case of emergency;

**(e) Flashlight**

Flashlight, if equipped at FWCV, must be switched on inside O-PARK1 during daytime and night time;

**(f) Headlamp**

Switch on dipped lights during the hours of darkness (including dusk) or in poor visibility conditions (eg. in rain or fog), and should use headlamps inside unloading bays.

### 5.3 Use of Weighbridge System



- (a) Drivers should follow the traffic signals to stop the FWCV at weighbridge and should not hit the gate bars in any circumstance (Note: only one FWCV can stop at the weighbridge at one time);
- (b) At inbound weighbridge, drivers should present duly filled “Food Waste Collection and Delivery Record” form to the weighbridge operator;
- (c) After weighing at the inbound weighbridge, drivers should drive FWCV to the designated queue up area;
- (d) At the outbound weighbridge, drivers should collect the stamped “Food Waste Collection and Delivery Record” form from the weighbridge operator;

- (e) Drivers should follow the traffic light signals or instruction from O-PARK1 staff when leaving the weighbridge.

## 5.4 FWCV Traffic Flow

### (a) FWCV Queuing Plan

Drivers are required to follow the queuing plan, drive FWCV to queuing area and wait for the traffic signal and/or instruction of O-PARK1 staff to enter the unloading bays.

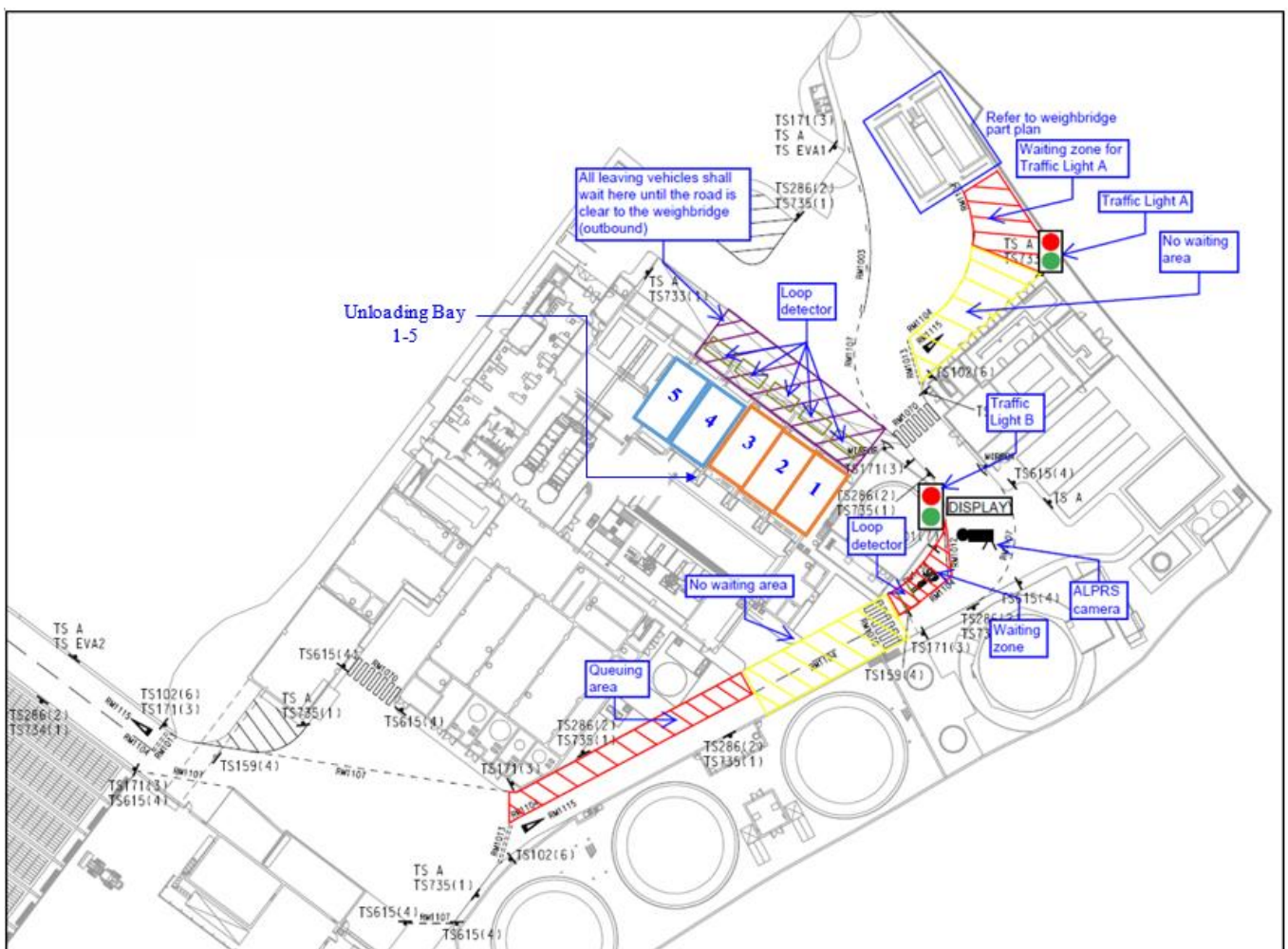

**FWCV Queuing Plan**

(b) FWCV Queuing Plan - Traffic Route

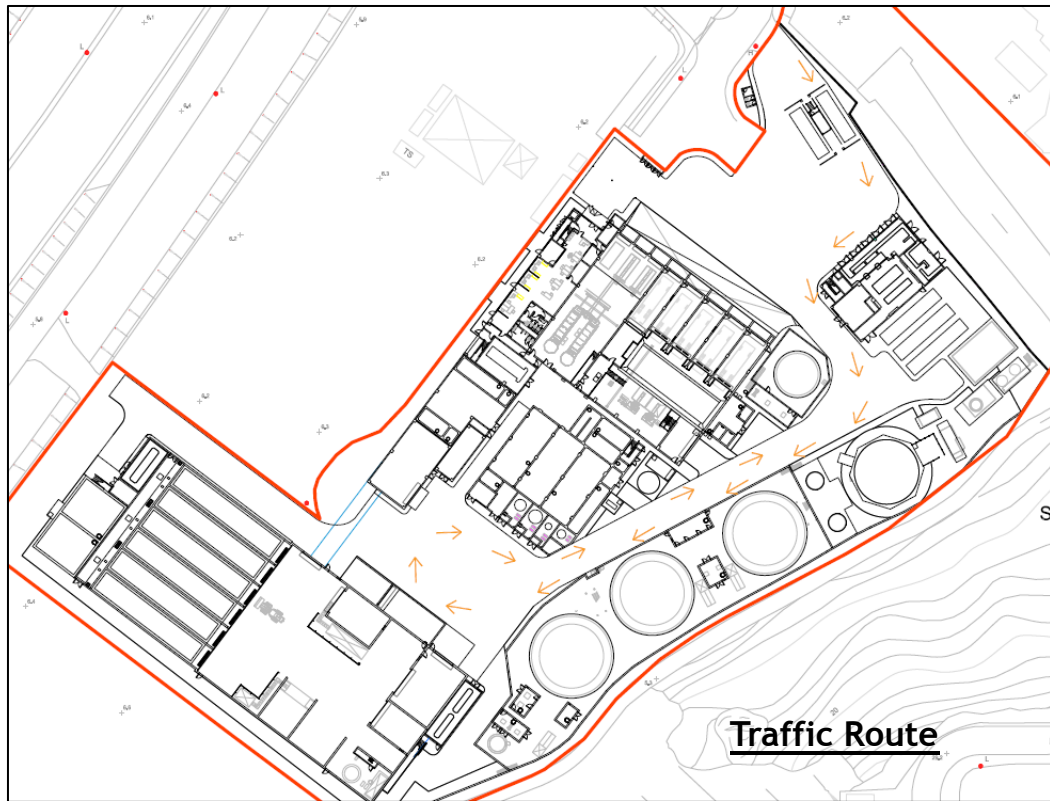

(c) FWCV Queuing Plan - Heading for Unloading

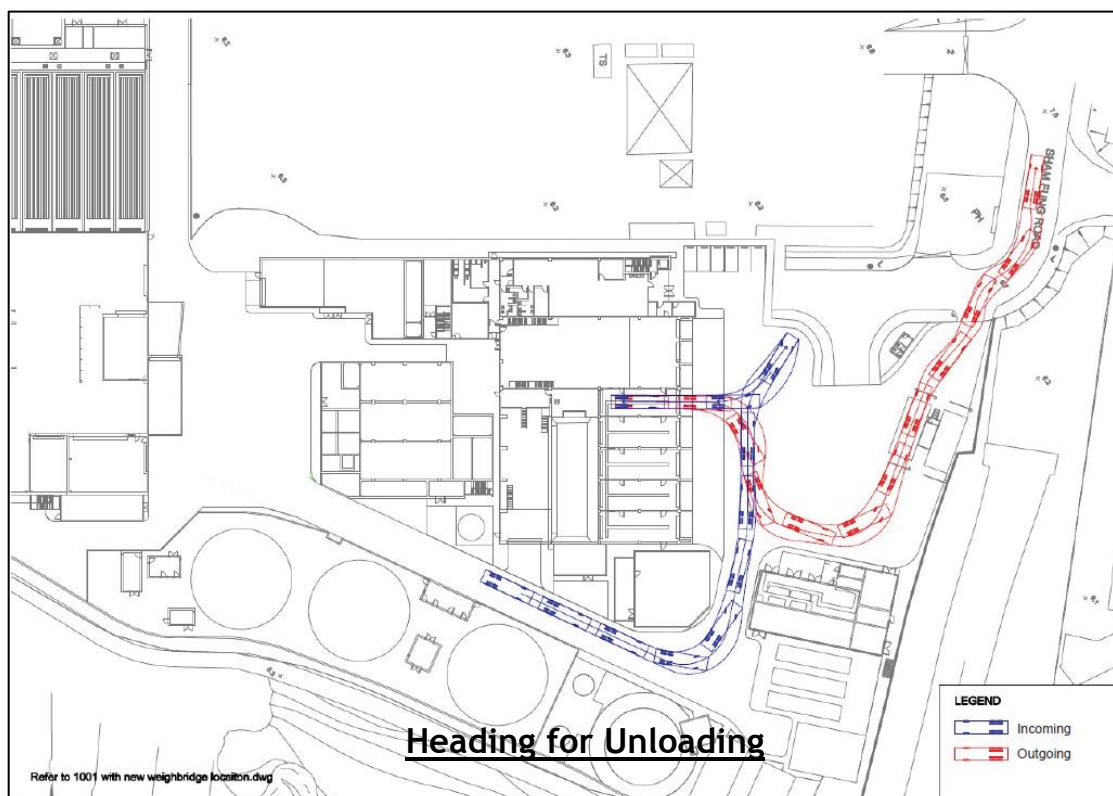

## 6. Food Waste Reception and Unloading

### 6.1 Food Waste Reception Area

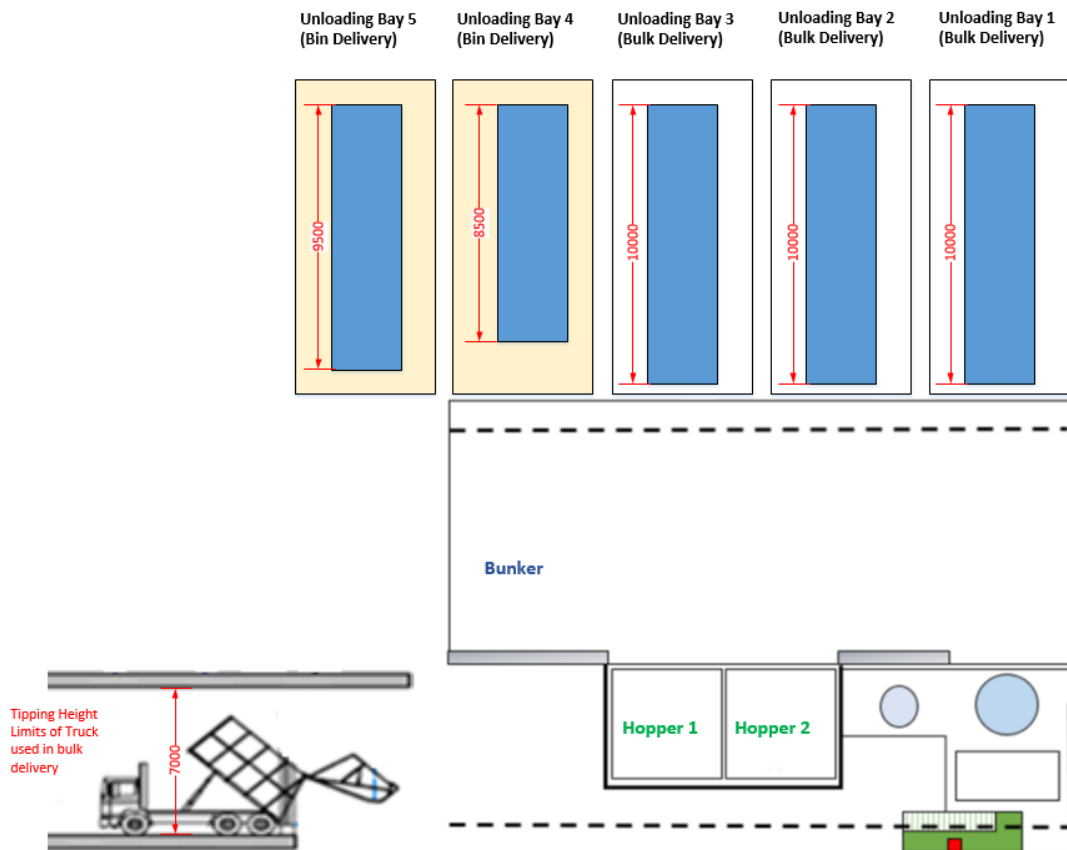

There are five unloading bays for FWCV to unload the food waste to the bunker. At present, two unloading bays are assigned for bin delivery and three unloading bays are assigned for bulk delivery. But if the demand of bin delivery is more than bulk delivery, the combination of the unloading bays will be reviewed and/ or amended to meet the need accordingly.

## 6.2 Work Flow of Food Waste Unloading

### Enter the Food Waste Unloading Bay

- (a) Each unloading bay has two sets of roller shutter doors (front & rear) to control the odour migration;
- (b) Driver reverses FWCV to the front of designated unloading bay;
- (c) FWCV triggers the position sensor and the front roller shutter door opens;
- (d) Driver reverses FWCV into the unloading bay completely while the sensor system confirms FWCV to park at safe position and informs the driver to stop via signals (sound and light);



- (e) Front roller shutter door closes and rear roller shutter door opens;

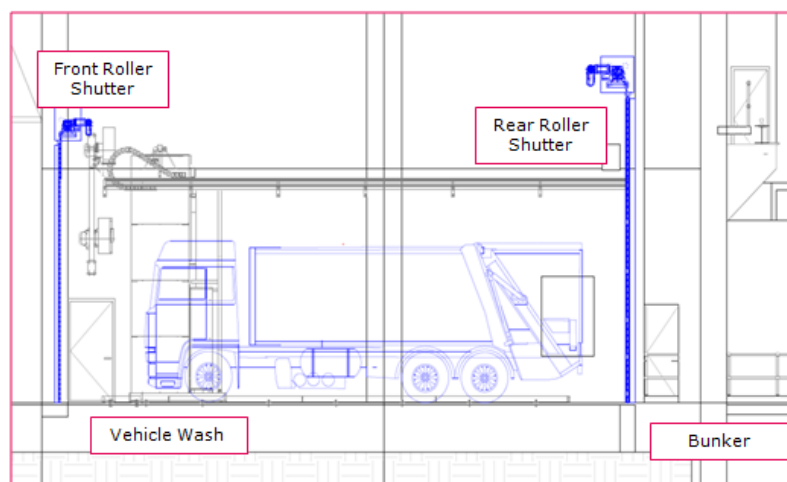



### Unloading Food Waste - Bulk Delivery

- (f) Driver further reverses FWCV to the tipping position and then starts unloading food waste into the bunker by raising the seal tank;
- (g) Driver lowers FWCV seal tank after unloading;

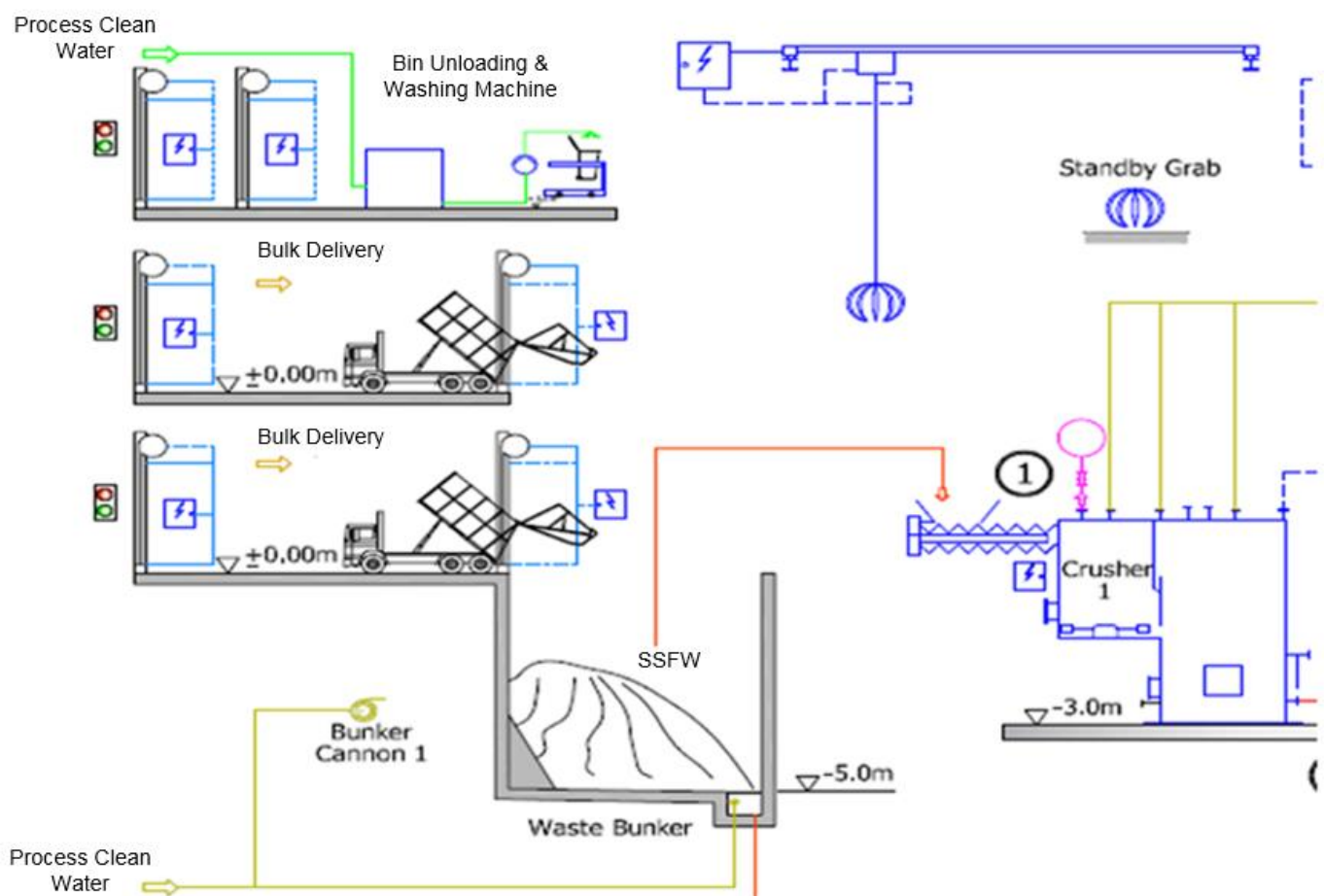

**Unloading Food Waste - Bin Delivery**

- (h) Driver uses FWCV tail gate to unload the food waste collection bins and moves the bins to the tipping machine while O-PARK1 staff operates the tipping machine to discharge the food waste from the bins into the bunker;
- (i) After tipping, high pressure water jet will rinse the interior of the bins and then, driver will move the empty bins back to FWCV;

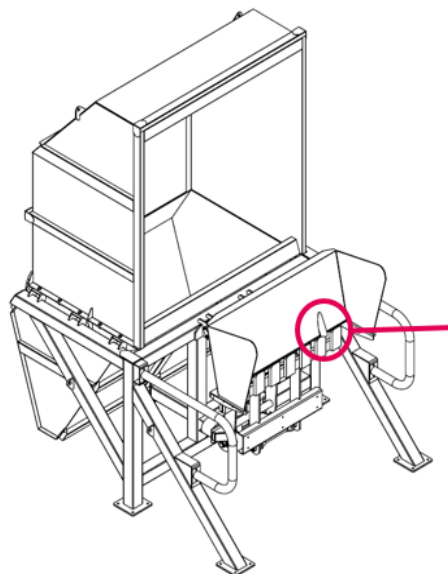

**Leaving Unloading Bay**

- (j) Once the unloading of food waste is completed, and driver drives FWCV forward to designated position and stops;
- (k) Position sensor of the rear roller shutter door is triggered and the door starts to close;
- (l) Once the rear roller shutter door closes completely, automatic vehicles wash machine can be activated;
- (m) When the automatic vehicle wash completes, front roller shutter door starts to open;

Automatic  
vehicle  
wash  
machine

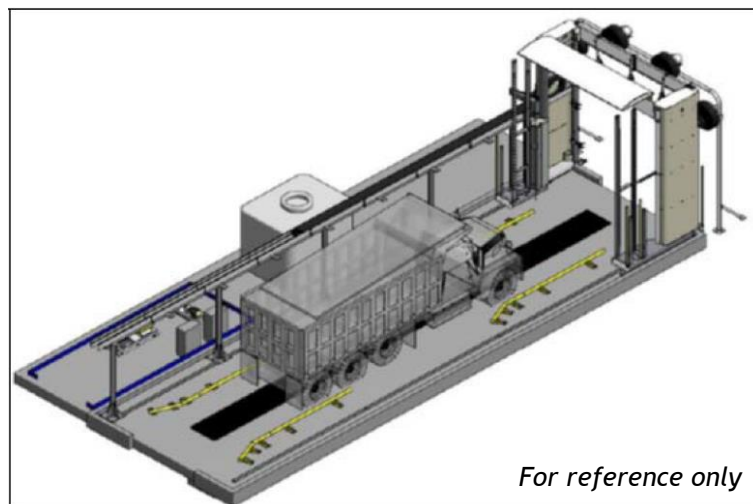

High  
Pressure  
Washing



- (n) Once the front roller shutter door opens completely, driver will receive traffic signal for driving FWCV to leave the unloading bay. When the FWCV is leaving the unloading bay, the air blowers are activated to dry the leaving FWCV's body;
- (o) Driver should make sure the road is clear and safe, drives FWCV to outbound weighbridge, collects the stamped "Food Waste Collection & Delivery Record Form" and leaves O-PARK1.

## Air Blowers

